

Description	The pressure booster doubles the system pressure of e.g. 5 bar to an outlet pressure of 10 bar. The pumping force of two cylindrical chambers compresses the air down to the set outlet pressure within the third chamber while the fourth chamber is vented. Upon reaching the outlet pressure it is turned off, when falling below it is turned on automatically. Pressure boosters are used for occasional demand of compressed air.	
Media	lubricated and 50 µm filtered compressed air	Mounting position any
Drive	double piston intensifier, ratio 1:2	Reversing, check and switching valves provide for automatic control. Life time approx. 20 million switching cycles.
Inlet pressure P₁	2...8 bar	Outlet pressure P₂ 4...16 bar
Air tanks	are recommended. They compensate pressure fluctuations and allow short-term high volume flows. See circuit below.	
Tank filling time	is a measure of booster performance. To reduce the filling time of the tank, it has to be pre-filled with input pressure P ₁ . See circuit below.	
Temperature range	-5 °C to 50 °C / 23 °F to 122 °F	
Material	Cylinder: anodized aluminium	seals: NBR/Buna-N

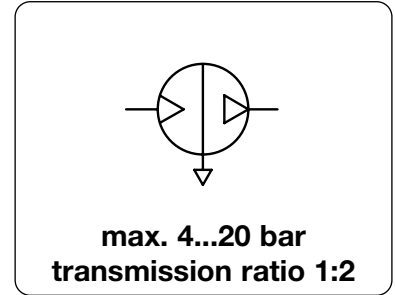

Dimensions			Weight kg	Connection thread G	Transmission ratio P _A : P ₂	Flow rate l/min*1	Fill time 10l-tank s	Pressure range bar	Order number
A mm	B mm	C mm							

Pressure booster									
P ₁ max. 8 bar, for compressed air									
AB									
100	192	70	1.5	G½	1 : 2	130	30	4...16	AB040
117	284	90	3.0	G¾	1 : 2	260	15	4...16	AB063
176	468	155	12	G½	1 : 2	440	6	4...16	AB100



AB040

Pressure booster with regulator and gauge									
P ₁ max. 8 bar, for compressed air									
AB-D									
100	192	126	1.5	G½	1 : 2	130	30	4...16	AB040D
117	284	168	3.0	G¾	1 : 2	260	15	4...16	AB063D
176	468	218	12	G½	1 : 2	440	6	4...16	AB100D



AB040D

Accessories, enclosed

Mounting plate	made of steel, central attachment below	for AB040	BW00-49
		for AB063	BW00-50
Mounting bracket	made of steel, mounting at the side, 1 piece	for AB100	BW00-51

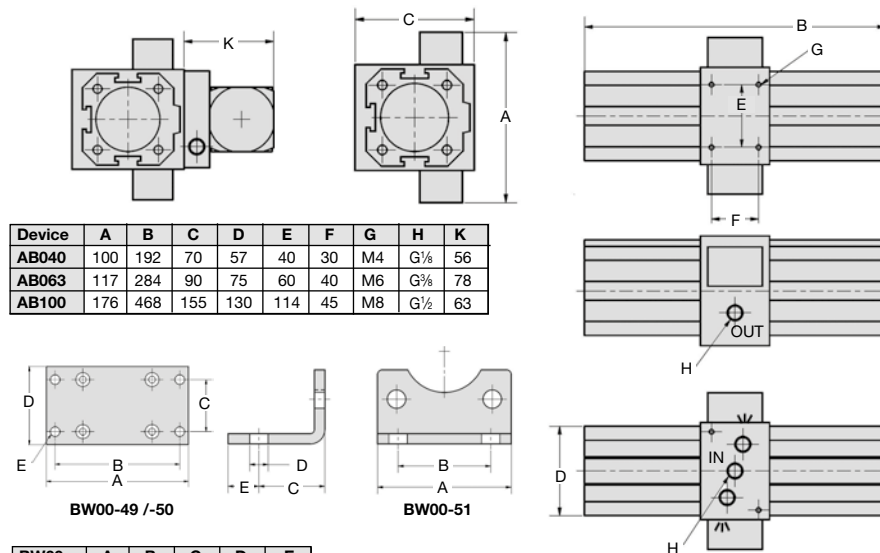
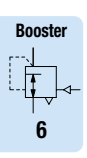

Device	A	B	C	D	E	F	G	H	K
AB040	100	192	70	57	40	30	M4	G½	56
AB063	117	284	90	75	60	40	M6	G¾	78
AB100	176	468	155	130	114	45	M8	G½	63

BW00-	A	B	C	D	E
49	82	72	30	45	5,5
50	110	98	53	70	M8
51	65	45	32	9	15

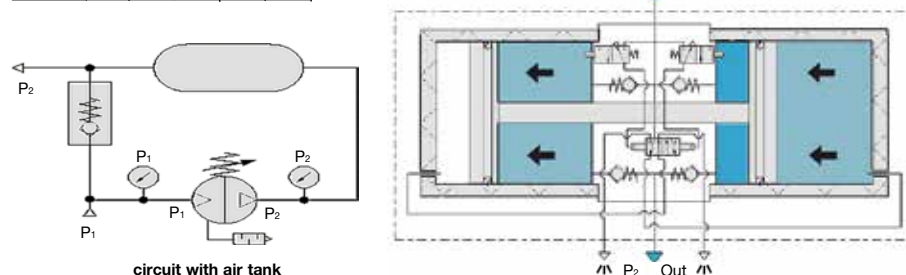

*1 at P₂ = 8 bar and 1 bar pressure drop

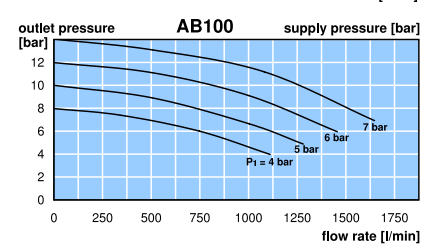
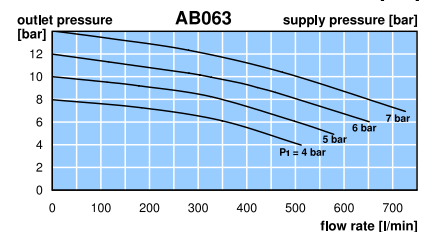
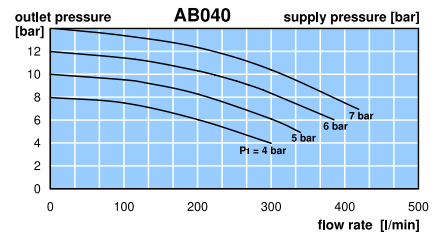
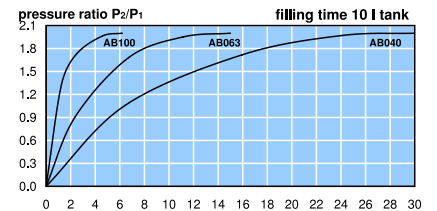

* Product group

Pressure booster with 2 l to 20 l tank on request

PDF CAD
www.aircom.net



Order example:
AB040